

WARD APPARATUS
 1250 SCHWEIZER ROAD PHONE (607) 796-0149
 HORSEHEADS, NY 14845 FAX (607) 739-7092

CUSTOMER APPROVED BY:

VEHICLE TYPE: RESCUE	CHASSIS: FORD F-550 CREW CAB 4X4
VIEW: STREETSIDE	BODY MAT'L: ALUMINUM
SCALE: NTS	BODY LENGTH: 123"
DRAWN BY: NRW	APPROVED BY:
DATE: 8/10/2022	BODY STYLE:
DWG NO.: RIVERSIDECO	REVISION:

RIVERSIDE COUNTY, CALIFORNIA

NOTE: ALL DIMENSIONS ARE APPROXIMATE

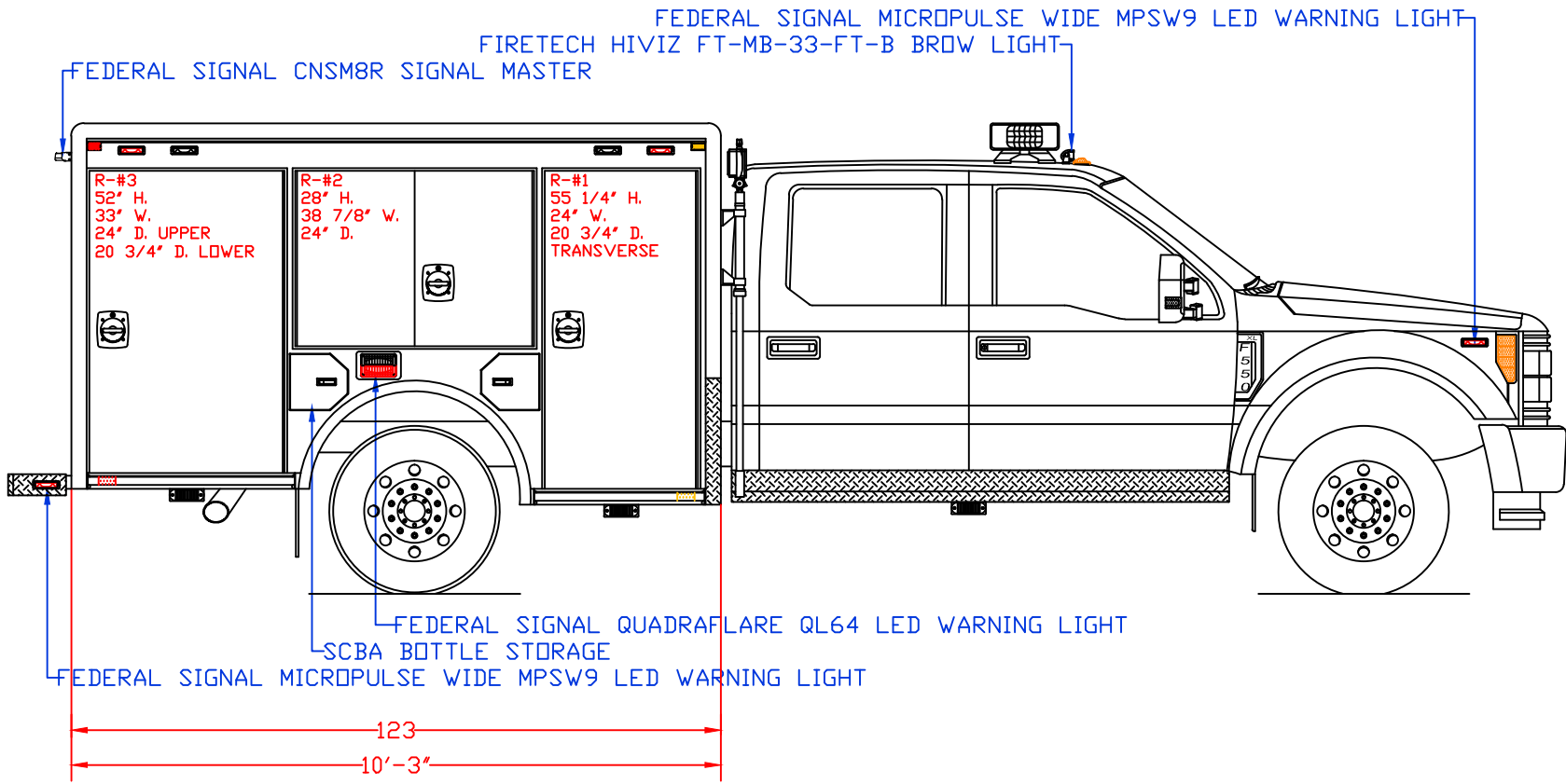

WARD APPARATUS
 1250 SCHWEIZER ROAD PHONE (607) 796-0149
 HORSEHEADS, NY 14845 FAX (607) 739-7092

CUSTOMER APPROVED BY:

VEHICLE TYPE: RESCUE	CHASSIS: FORD F-550 CREW CAB 4X4
VIEW: CURBSIDE	BODY MAT'L: ALUMINUM
SCALE: NTS	BODY LENGTH: 123"
DRAWN BY: NRW	APPROVED BY:
DATE: 8/10/2022	BODY STYLE:
DWG NO.: RIVERSIDECO	REVISION:

RIVERSIDE COUNTY, CALIFORNIA

NOTE: ALL DIMENSIONS ARE APPROXIMATE

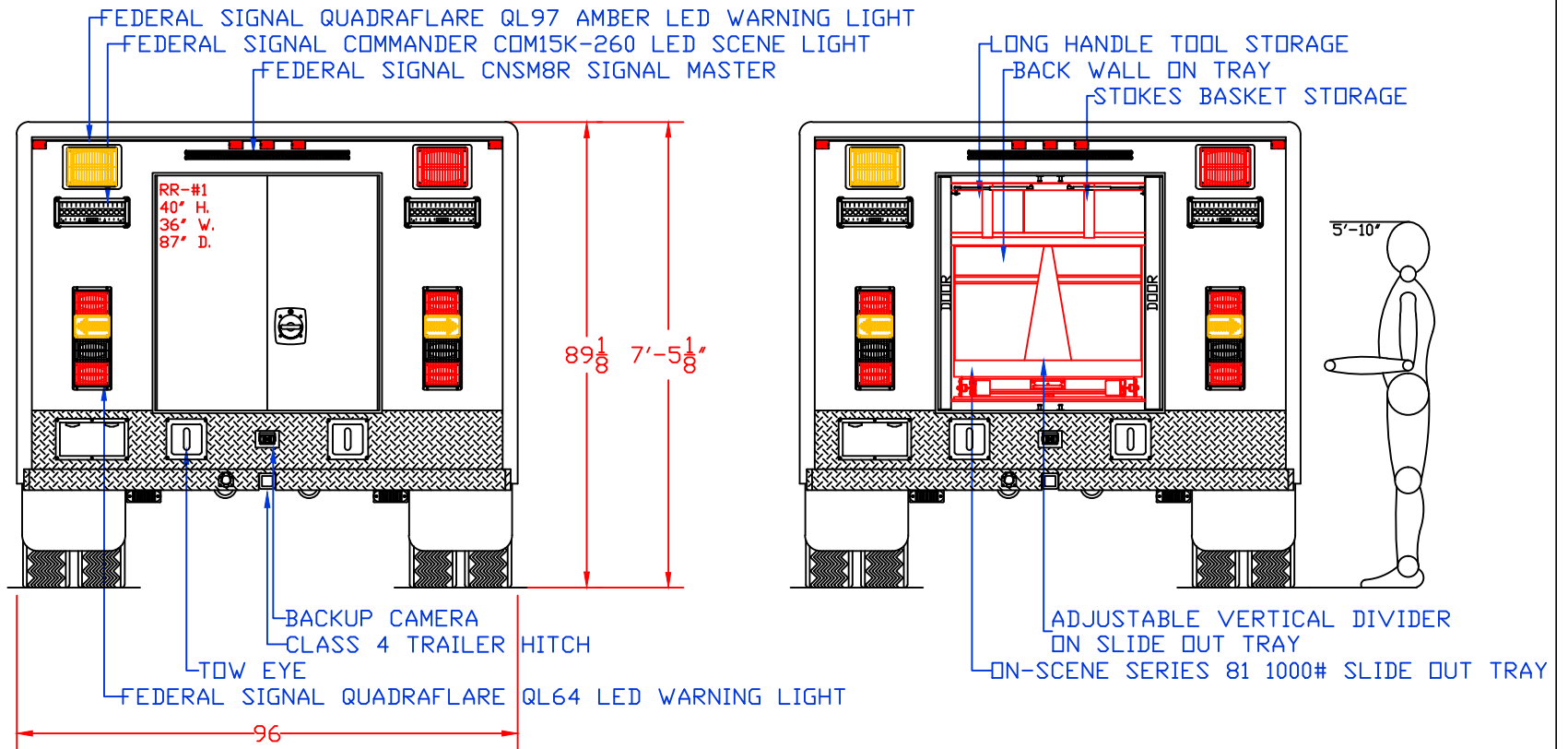

WARD APPARATUS

1250 SCHWEIZER ROAD PHONE (607) 796-0149
 HORSEHEADS, NY 14845 FAX (607) 739-7092

RIVERSIDE COUNTY, CALIFORNIA

CUSTOMER APPROVED BY:

VEHICLE TYPE: RESCUE	CHASSIS: FORD F-550 CREW CAB 4X4
VIEW: REAR & REAR COMPARTMENT LAYOUT	BODY MAT'L: ALUMINUM
SCALE: NTS	BODY LENGTH: 123"
DRAWN BY: NRW	APPROVED BY:
DATE: 8/10/2022	BODY STYLE:
DWG NO.: RIVERSIDECO	REVISION:

NOTE: ALL DIMENSIONS ARE APPROXIMATE

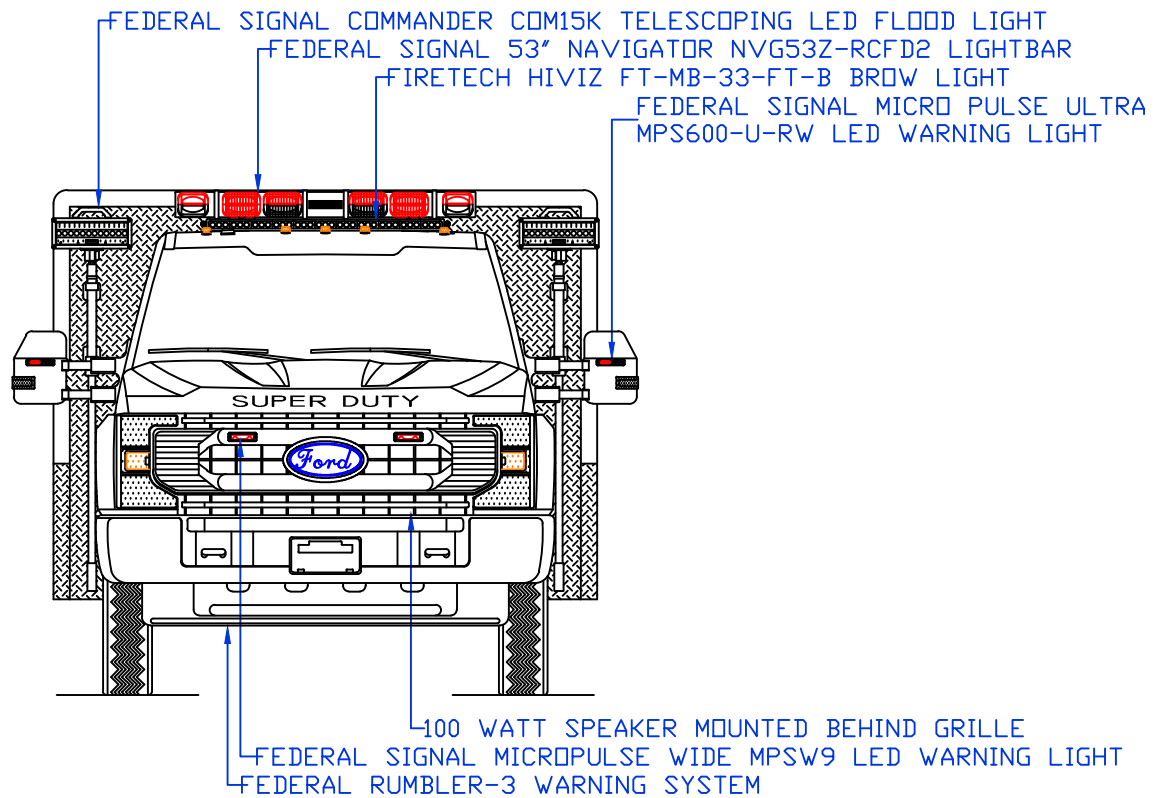

WARD APPARATUS

1250 SCHWEIZER ROAD PHONE (607) 796-0149
 HORSEHEADS, NY 14845 FAX (607) 739-7092

RIVERSIDE COUNTY, CALIFORNIA

CUSTOMER APPROVED BY:

VEHICLE TYPE: RESCUE	CHASSIS: FORD F-550 CREW CAB 4X4
VIEW: FRONT	BODY MAT'L: ALUMINUM
SCALE: NTS	BODY LENGTH: 123"
DRAWN BY: NRW	APPROVED BY:
DATE: 8/10/2022	BODY STYLE:
DWG NO.: RIVERSIDECO	REVISION:

NOTE: ALL DIMENSIONS ARE APPROXIMATE

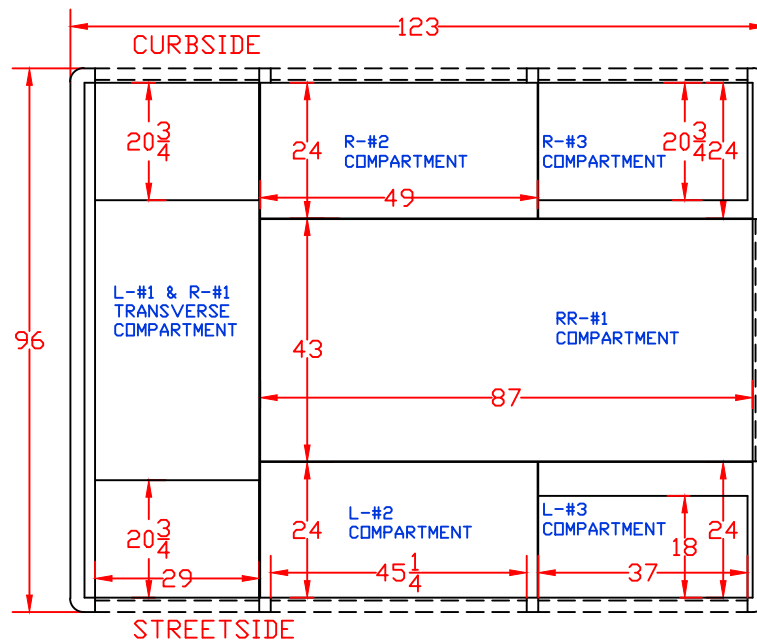

WARD APPARATUS

1250 SCHWEIZER ROAD PHONE (607) 796-0149
 HORSEHEADS, NY 14845 FAX (607) 739-7092

RIVERSIDE COUNTY, CALIFORNIA

CUSTOMER APPROVED BY: _____

VEHICLE TYPE: RESCUE	CHASSIS: FORD F-550 CREW CAB 4X4
VIEW: TOP	BODY MAT'L: ALUMINUM
SCALE: NTS	BODY LENGTH: 123"
DRAWN BY: NRW	APPROVED BY:
DATE: 8/10/2022	BODY STYLE:
DWG NO.: RIVERSIDECO	REVISION:

NOTE: ALL DIMENSIONS ARE APPROXIMATE

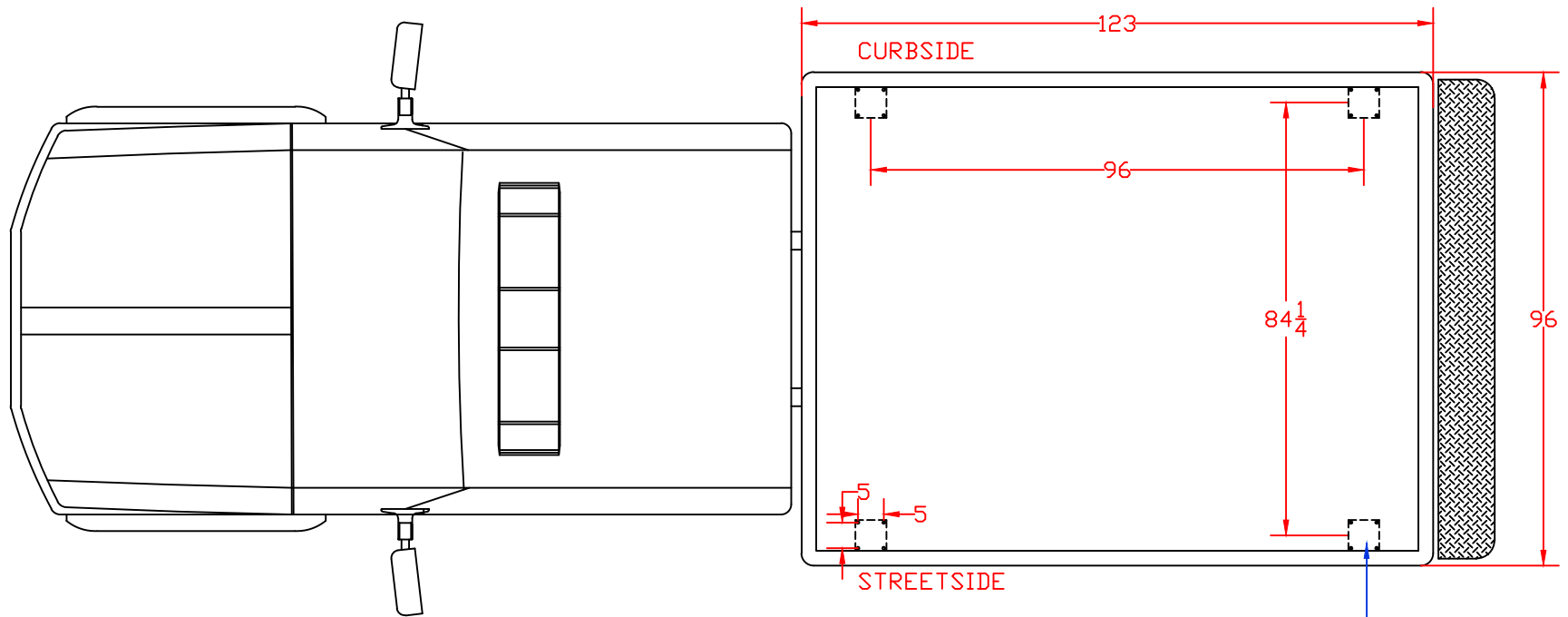

FOUR 1/4" BACKER PLATES WITH FOUR 3/8" BOLTS TAPPED INTO PLATES 5" ON CENTER



WARD APPARATUS

1250 SCHWEIZER ROAD PHONE (607) 796-0149
 HORSEHEADS, NY 14845 FAX (607) 739-7092

RIVERSIDE COUNTY, CALIFORNIA

CUSTOMER APPROVED BY:

VEHICLE TYPE: RESCUE	CHASSIS: FORD F-550 CREW CAB 4X4
VIEW: ROOF	BODY MAT'L: ALUMINUM
SCALE: NTS	BODY LENGTH: 123"
DRAWN BY: NRW	APPROVED BY:
DATE: 8/10/2022	BODY STYLE:
DWG NO.: RIVERSIDECO	REVISION:

NOTE: ALL DIMENSIONS ARE APPROXIMATE

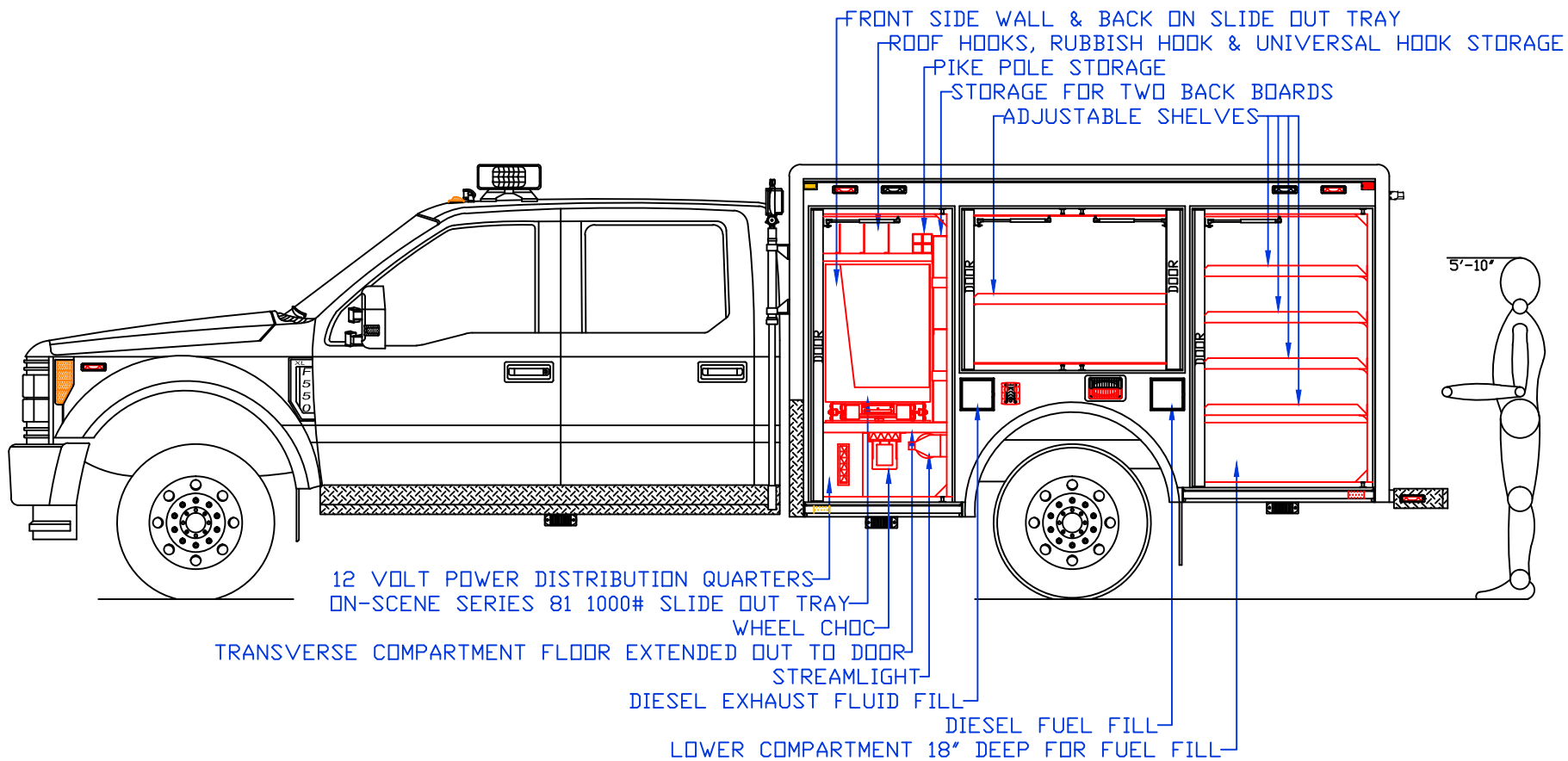

WARD APPARATUS

1250 SCHWEIZER ROAD PHONE (607) 796-0149
 HORSEHEADS, NY 14845 FAX (607) 739-7092

RIVERSIDE COUNTY, CALIFORNIA

CUSTOMER APPROVED BY:

VEHICLE TYPE: RESCUE	CHASSIS: FORD F-550 CREW CAB 4X4
VIEW: STREETSIDE COMPARTMENT LAYOUT	BODY MAT'L: ALUMINUM
SCALE: NTS	BODY LENGTH: 123"
DRAWN BY: NRW	APPROVED BY:
DATE: 8/10/2022	BODY STYLE:
DWG NO.: RIVERSIDECO	REVISION:

NOTE: ALL DIMENSIONS ARE APPROXIMATE

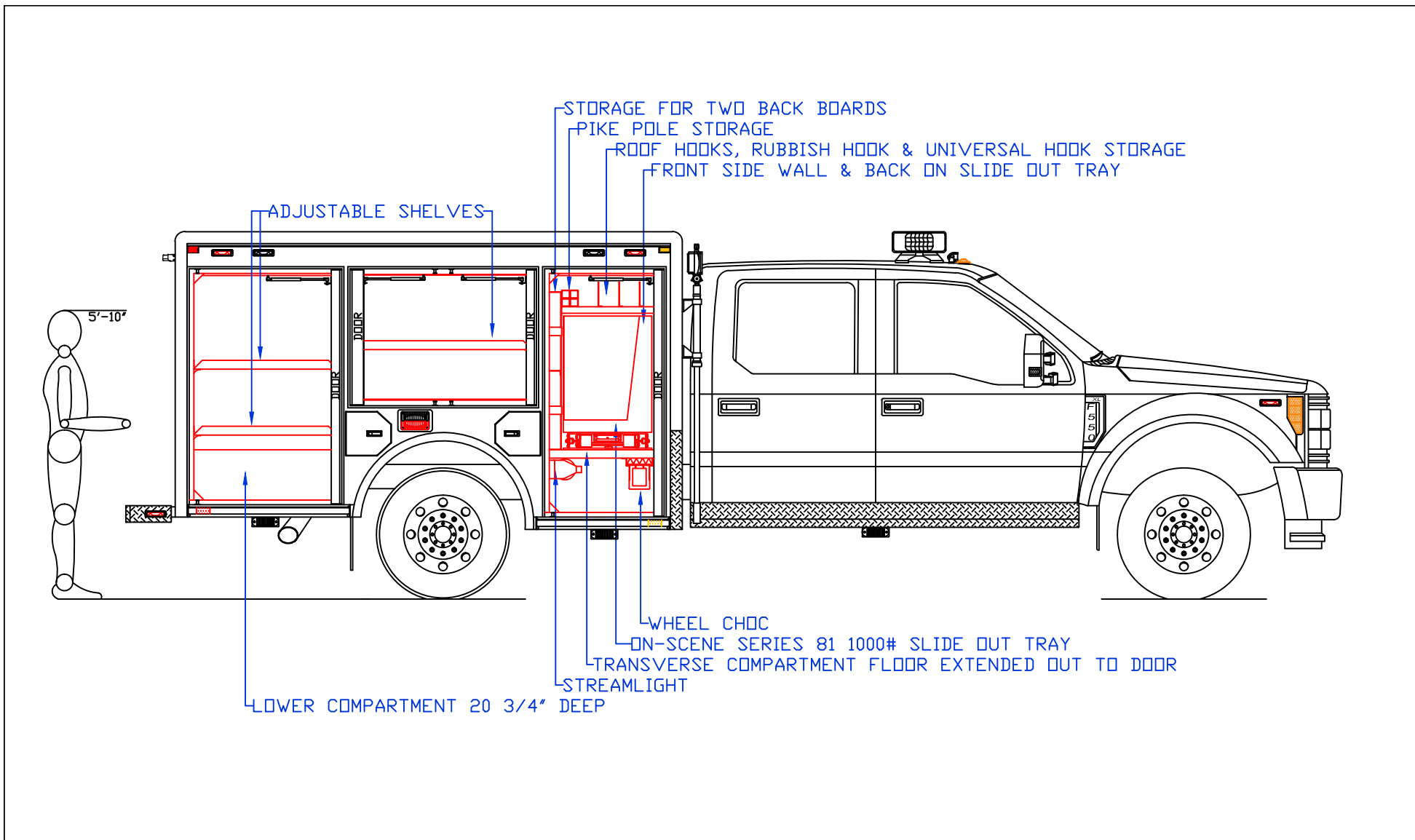

WARD APPARATUS

1250 SCHWEIZER ROAD PHONE (607) 796-0149
 HORSEHEADS, NY 14845 FAX (607) 739-7092

RIVERSIDE COUNTY, CALIFORNIA

CUSTOMER APPROVED BY:

VEHICLE TYPE: RESCUE	CHASSIS: FORD F-550 CREW CAB 4X4
VIEW: CURBSIDE COMPARTMENT LAYOUT	BODY MAT'L: ALUMINUM
SCALE: NTS	BODY LENGTH: 123"
DRAWN BY: NRW	APPROVED BY:
DATE: 8/10/2022	BODY STYLE:
DWG NO.: RIVERSIDECO	REVISION:

NOTE: ALL DIMENSIONS ARE APPROXIMATE

L-#1 SLIDE OUT TRAY

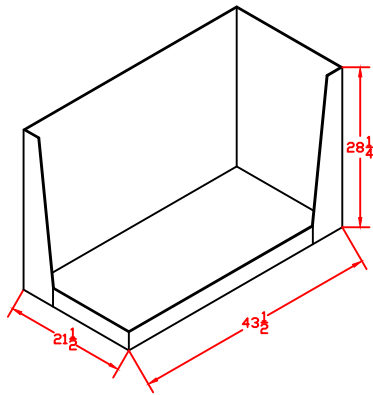

R-#1 SLIDE OUT TRAY

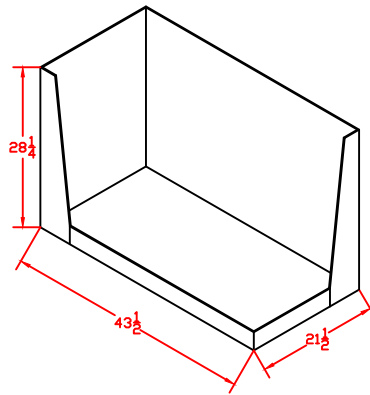

RR-#1 SLIDE OUT TRAY
ADJUSTABLE DIVIDER

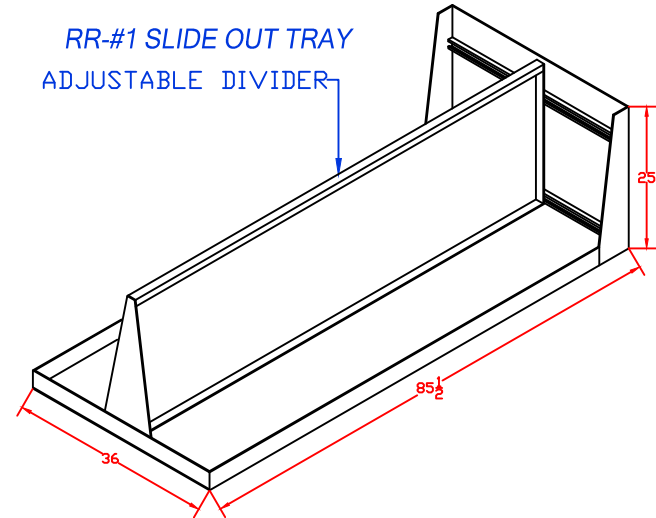

L & R-#1 COMP. ROOF HOOKS, RUBBISH HOOK, UNIVERSAL HOOK PRY BARS, PIKE POLE & BACK BOARDS

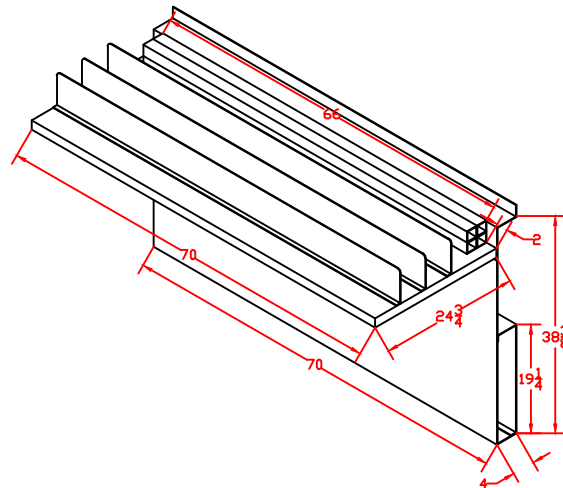

NOTE: ALL DIMENSIONS ARE APPROXIMATE AND SUBJECT TO ADJUSTMENT



WARD APPARATUS

1250 SCHWEIZER ROAD PHONE (607) 796-0149
HORSEHEADS, NY 14845 FAX (607) 739-7092

RIVERSIDE COUNTY, CALIFORNIA

CUSTOMER APPROVED BY:	
VEHICLE TYPE: RESCUE	CHASSIS: FORD F-550 CREW CAB 4X4
VIEW: SLIDE OUT TRAY & LR-#1 STORAGE	BODY MAT'L: ALUMINUM
SCALE: NTS	BODY LENGTH: 123"
DRAWN BY: NRW	APPROVED BY:
DATE: 8/10/2022	BODY STYLE:
DWG NO.: RIVERSIDECO	REVISION:

NOTE: ALL DIMENSIONS ARE APPROXIMATE